

Leverage the Power of Built For Integration

The CL Series is a BACnet and N2 native relay panel designed specifically for integration with BACnet and N2 building automation systems. Built upon the Lx5 Technology platform, CL Series provides superior lighting integration and delivers the rapid response lighting applications demand. CL Series integration is essentially guaranteed.

- B** **A**Cnet **MS/TP**
@ 9,600 baud
@ 19,200 baud
@ 38,400 baud
@ 76,800 baud
- N** **N**2
@ 9,600 baud
- L** **u**misys **O**pen
@ 9,600 baud
- T** **r**iatek **L**egacy
@ 9,600 baud

Powered by the multi-protocol native Lx5 Technology platform, these UL Listed, lighting relay panels provide the capability to directly control high voltage lighting circuits. CL Series is manufactured specifically to integrate with the BACnet and N2 protocols; reducing frustration for the building engineer by eliminating the need to learn, operate, and maintain a separate lighting control system. CL Series lighting relay panels powered by the Lx5 Technology platform support multiple native protocols. These protocol options are manually selectable on the Lx5 controller or are field flash upgradable with the Technician's Kit (sold separately).



CL08

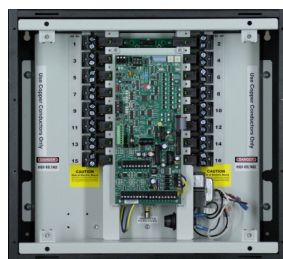

CL16

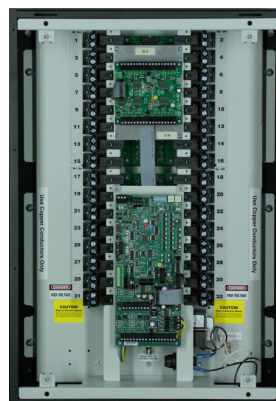

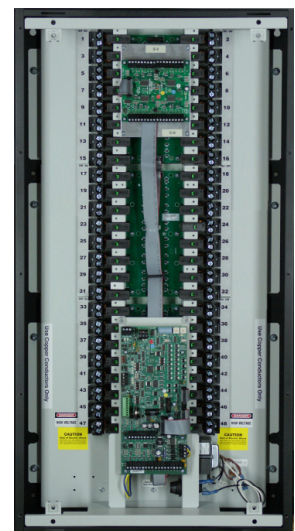

CL32



CL48

Panel Comparison

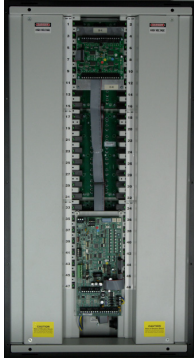
	CL08	CL16	CL32	CL48
Panel				
Dimensions				
Enclosure (Width x Height x Depth)	13.0" x 14.75" x 5.75"	18.0" x 16.2" x 5.75"	18.0" x 25.0" x 5.75"	18.0" x 33.8" x 5.75"
Door - Surface Mount (Width x Height)	13.16" x 14.92"	18.08" x 16.45"	18.08" x 25.25"	18.08" x 34.05"
Door - Recess Mount (Width x Height)	-	19.58" x 17.7"	19.58" x 26.5"	19.58" x 35.3"
Native, Selectable Protocols				
BACnet MS/TP*	√	√	√	√
N2	√	√	√	√
Lumisys Open	√	√	√	√
TRIA TEK legacy	√	√	√	√
BACnet Features				
Supports BACnet Schedules	√	√	√	√
Supports BACnet Alarms	√	√	√	√
Supports BACnet Trends	√	√	√	√
Inputs				
Switch Inputs (standard)	24	24	24	24
Analog Inputs (standard)	6	6	6	6
Outputs				
Relays Factory Installed	8	8 or 16	16, 24, or 32	24, 32, 40 or 48
Short Circuit Current Rating @ 277 VAC	20,000 Amps	20,000 Amps	20,000 Amps	20,000 Amps
UL Listed Relay	√	√	√	√
Additional Information				
Door Style	Screw-on	Reversible Hinge w/ Lock	Reversible Hinge w/ Lock	Reversible Hinge w/ Lock
Controller	CLCTRL	CLCTRL	CLCTRL	CLCTRL
Flash Upgrade Firmware	√	√	√	√
Approximate Shipping Weight	25 lbs	37 lbs	54 lbs	70 lbs

*Refer to Lx5 BACnet PIC (protocol implementation conformance) statement

Panel Details

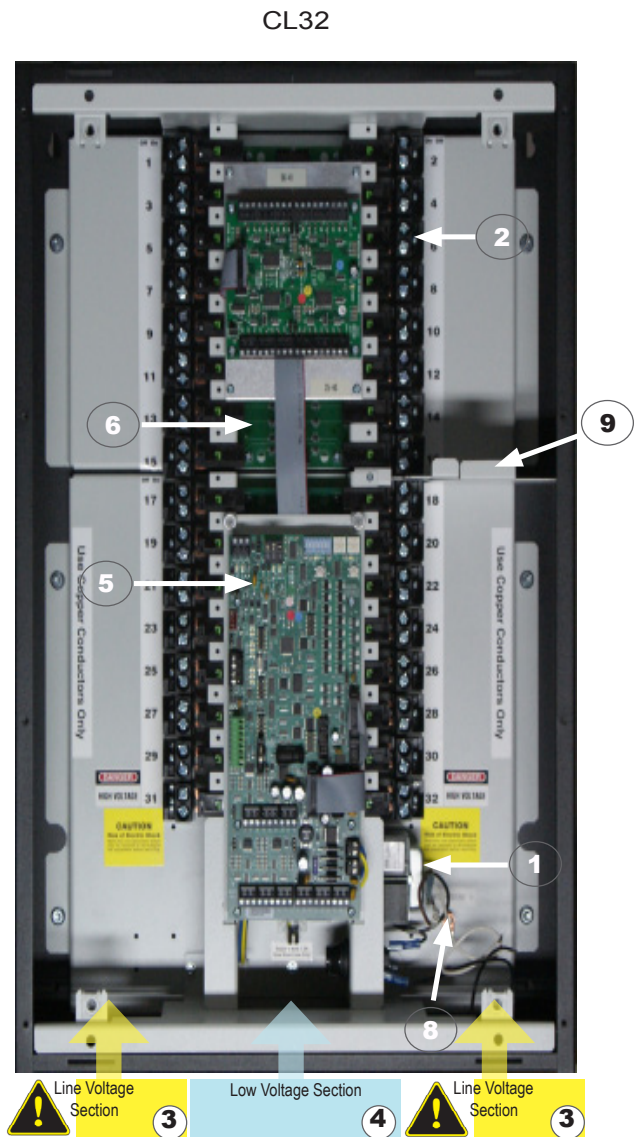

- 1) Control Power Transformer (see wiring detail below)
- 2) Lighting Tough Relay (LTR)
- 3) Line Voltage Section
- 4) Low Voltage Section
- 5) Lx5 Controller
- 6) Relay Interface Board (RIB) - not visible on CL08
- 7) Optional Relay Voltage Divider (CLRVD)
- 8) Ground Lug

Control Power Wiring Detail

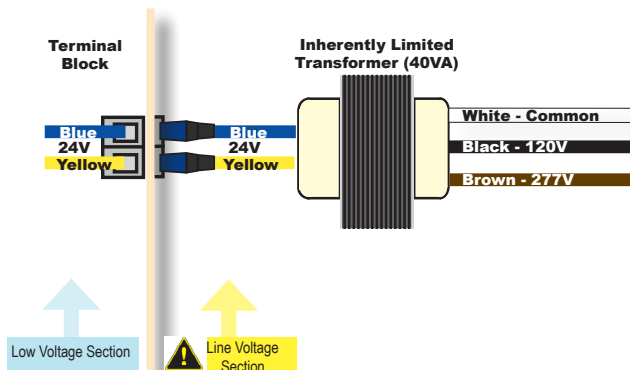

Electrical

Control Power

- Dual Tap Primary: 120 or 277 VAC \pm 10%, 30 VA, 50 / 60 Hz
- Secondary: 24 VAC \pm 10%

Short Circuit Current Rating (S.C.C.R.)

- 20,000 Amps @ 277 VAC

Lighting Tough Relay (LTR)

- UL Listed
- SPST latching with manual override lever
- Relay Drive is a staggered, energize pulse

Lighting Tough Relay (LTR) Load Ratings

- Tungsten 20 amp @ 120 VAC
- Ballast 20 amp @ 277 VAC
- Ballast 20 amp @ 347 VAC
- Resistive 20 amp @ 277 VAC
- Resistive 20 amp @ 347 VAC

Lighting Tough Relay (LTR) Load Terminals

- Universal screw with box clamp terminal
- Accepts single #14 AWG up to #8 AWG
- Accepts two #10 AWG.
- Solid or stranded wire, copper only

Mechanical

Enclosure

- Type: NEMA 1
- Dimensions: Refer to page 2

Environmental

Operating Parameters

- Temperature: 32° to 125° F (0° to 50° C)
- Humidity: 20% - 95%RH, non-condensing

System Certifications

Electronics

Electronics meet or exceed IEC Level 3 standards:

- Radiated Emissions, IEC 55022, Class A
- Conducted Emissions, IEC 55022, Class A
- Quasi-Stationary Current Harmonics, IEC 6100-3-2
- Voltage Fluctuation and Flicker, IEC 6100-3-2
- Electrostatic Discharge, IEC 61000-4-2
- Electrical Fast Transient/Burst, IEC 6100-4-4
- Surge Immunity, IEC 6100-4-5
- Immunity to Conducted Disturbance, IEC 6100-4-6
- Immunity to Voltage Dips, Short Interruptions, Voltage Variations, IEC 6100-4-11
- Electromagnetic Compatibility Generic Immunity Standard. Part 1, IEC 6100-6-1
- FCC, Part 15, Class A Radiated Emissions
- FCC, Part 15, Class A Conducted Emissions



Lighting Tough Relay (LTR)

Assembly

Assembly meets or exceeds the following standards:

- Underwriters Laboratories, UL 916, Standard for Energy Management Equipment
- FCC, Part 15, Class A Radiated Emissions
- FCC, Part 15, Class A Conducted Emissions
- CEC Title 24, California Energy Commission
- Optional: Underwriters Laboratories, UL 924, Standard for Emergency Lighting Control (NFPA70)

Lx5 Inputs

Switch input capacity by panel type and input type (maximum quantity):

Panel Type	Switch Inputs 1- 24		
	2-wire (maximum qty)	3-wire (maximum qty)	Combination (Max. Formula)
CL08	24	12	(qty of 2-wire) + ((qty of 3-wire) x2) must be ≤ 24
CL16	24	12	
CL32	24	12	
CL48	24	12	

Lx5 Controller

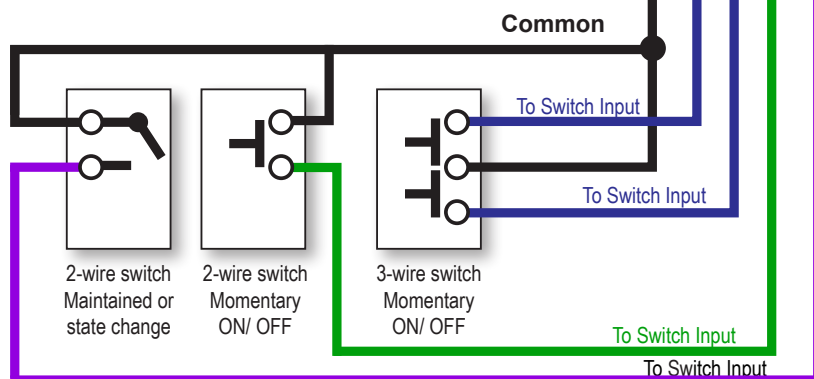
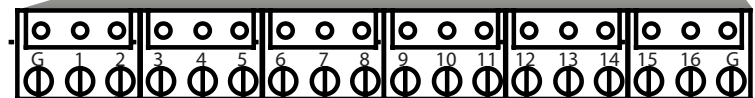
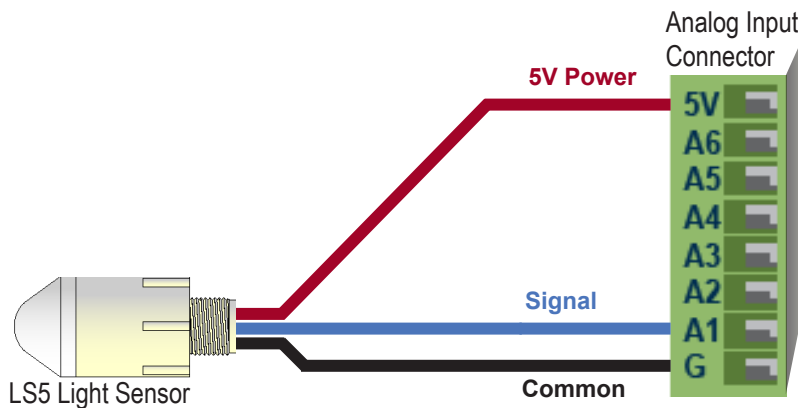
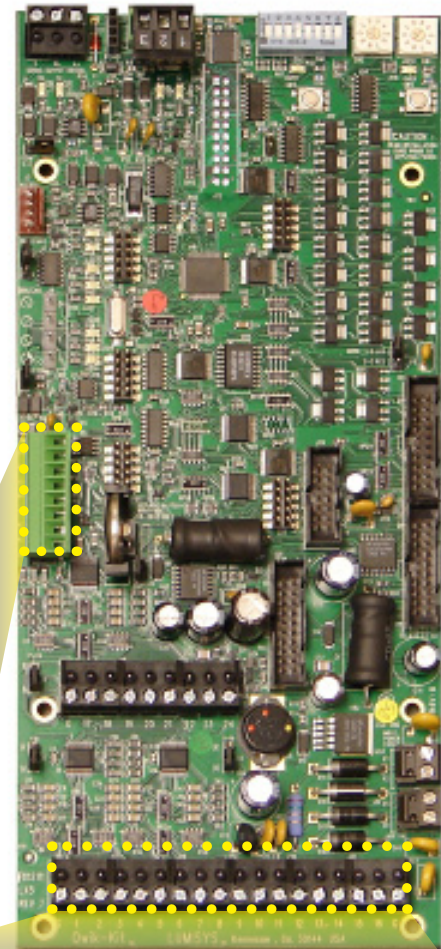

Switch Input Connectors

Analog Inputs

Typical wiring detail for a LS5 Light Sensor

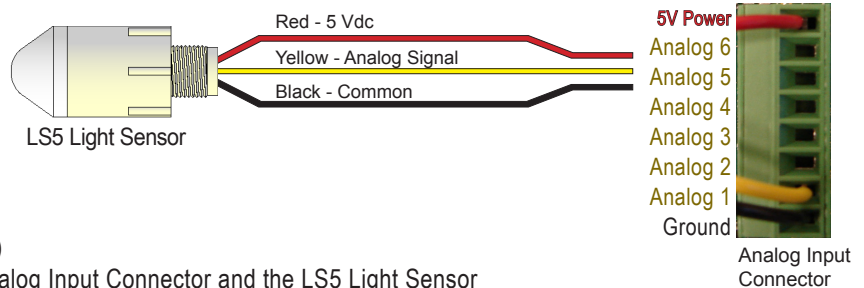

Wiring Recommendations:

Type: #18 AWG (non-twisted, un-shielded wire only)

Maximum Distance: 250 feet of wire between the Analog Input Connector and the LS5 Light Sensor

Switch Inputs - Dry Contact

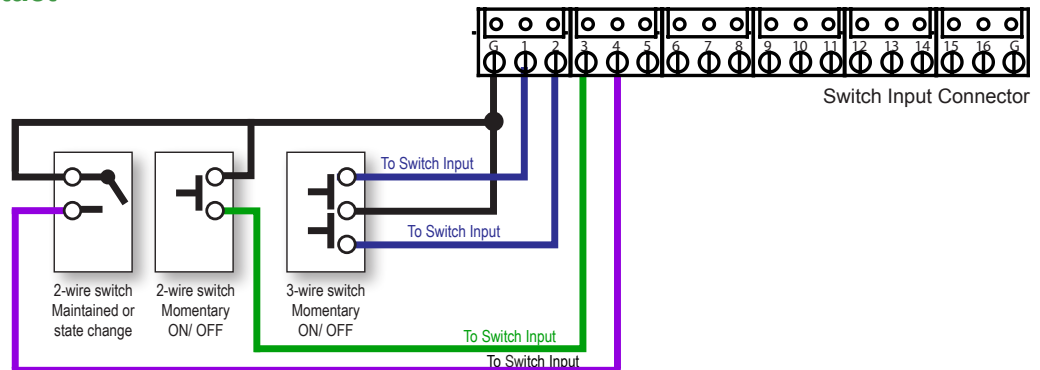

Wiring Recommendations:

Type: #18 AWG (non-twisted, un-shielded wire only)

Maximum Distance: 500 feet of wire between the Switch Input Connector and the Switch Terminals

Switch Inputs - Externally Powered

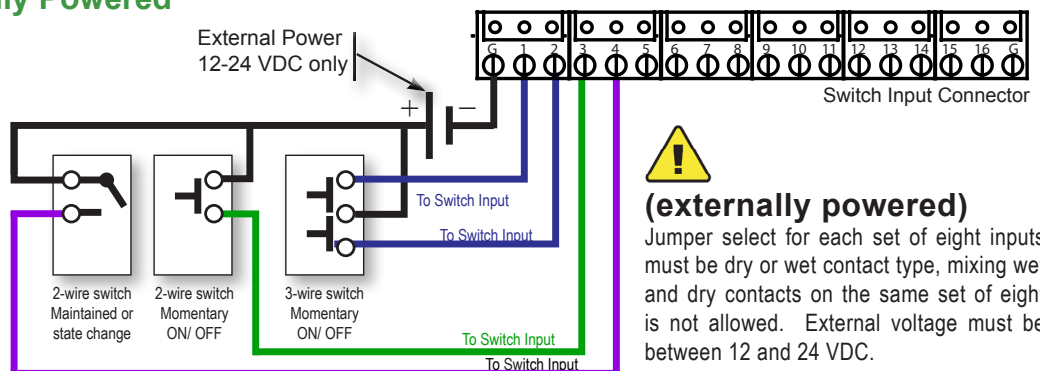

(externally powered)

Jumper select for each set of eight inputs must be dry or wet contact type, mixing wet and dry contacts on the same set of eight is not allowed. External voltage must be between 12 and 24 VDC.

Wiring Recommendations:

Type: #18 AWG (non-twisted, un-shielded wire only)

Maximum Distance: 1,000 feet of wire between the Switch Input Connector and the Switch Terminals

BACnet Integration

BACnet Point List (Standard):

Object ID	Description
BV:GG	Group GG Command - Binary
BV:1GG	Group GG Status - Binary
MSV:GG	Group GG Command - Multi-State
MSV:1GG	Group GG Status - Multi-State
MSV: 2RR	Relay RR Status - Multi-State
AV:GG	Group GG Count Down Timer (seconds)
AV:10A	Analog Input A Value

GG = Group number 1 - 60
 RR = Relay number 1 - 48
 A = Analog Input number 1 - 6

Group Command (MSV):

1 = Null / Do nothing
 2 = OFF w/ Flash (blink warning)
 3 = OFF
 4 = ON

Group Status (MSV):

1 = OFF due to serial command
 2 = ON due to serial command
 3 = OFF due to local override switch
 4 = ON due to local override switch
 5 = ON due to local override switch with timer count
 6 = OFF due to manual override on Lx5
 7 = ON due to manual override on Lx5

BACnet Network:

MAC Address: 01 - 99 via rotary dials on Lx5 controller

Baud Rates: Selected via dip switch on Lx5 controller;

BACnet MS/TP	9,000
BACnet MS/TP	19,200
BACnet MS/TP	38,400
BACnet MS/TP	76,800

Device ID: Default is 1320XX
 XX = 01 thru 99 MAC address

Supports custom BACnet device ID. Consult Blue Ridge Tech Support for details.

BACnet System Architecture

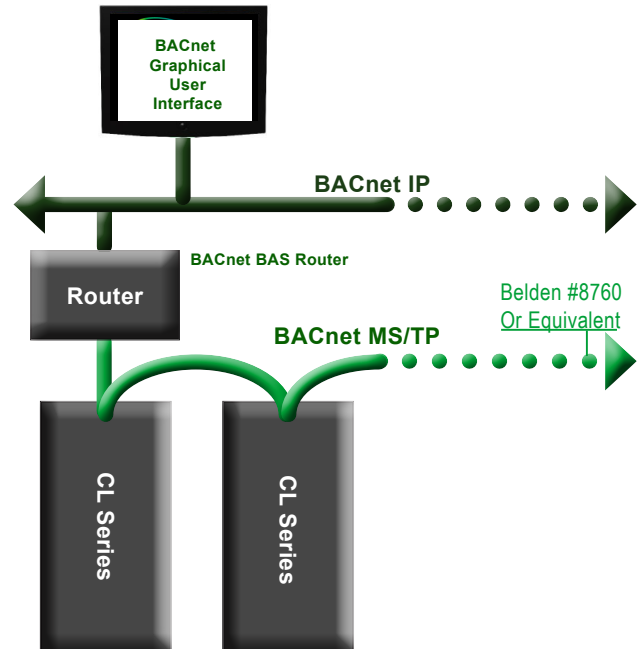

N2 System Architecture

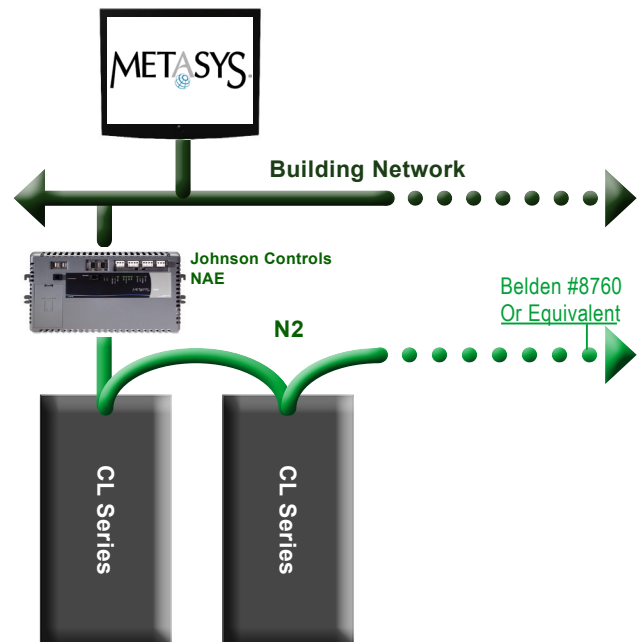



CL Series BACnet & N2 Relay Panel Data Sheet

Ordering Instructions

Catalog#	Description
CL08P-08	CL Series Panel, 8 LTR Capacity, 08 LTR Installed, 24 Switch Inputs, 6 Analog Inputs, Surface Mount Only

Catalog#	Description
CLXXP-XX-XX-X	CL Series Panel, XX LTR Capacity, XX LTR Installed, 24 Switch Inputs, 6 Analog Inputs

CLXXP-XX-XX-X

Trim

X = **S** for Surface Mount Panel and Trim
F for Flush Mount Panel and Trim (recessed)

Special Options

XX = **00** for No Special Options
X0 for UL924 - Last 16 relays only

Actual Quantity of Relays Installed

XX = **08 or 16** for 16 Relay Capacity
16, 24, or 32 for 32 Relay Capacity
24, 32, 40, or 48 for 48 Relay Capacity

Relay Panel Capacity

XX = **16** for 16 Relay Capacity
32 for 32 Relay Capacity
48 for 48 Relay Capacity